

10kA and 20kAmp Lightning Arrester

ON BOARD LIGHTNING ARRESTER

LIGHTNING ARRESTER



The Mersen lightning arrester enclosures are designed to protect railway networks against disturbances incurred by lightning, in the feeding lines in the substations along the railtrack (pole enclosure) as well as in the power lines mounted on the roof (pantograph enclosure).

These protection systems are to be installed between the feeding line and ground.

The usual solution consists of placing an air breaker and a non-linear resistance in silicon carbide between the line and the ground. The system presents several drawbacks :

It does not age well, and it becomes passing after several operations. This malfunction triggers the opening of the line circuit breaker, which interrupts the service.

The new solution is made up of the combination in series of a non linear zinc oxide resistance and a current limiting fuse.

The zinc oxide resists better to ageing thanks to a better non linearity coefficient.

In spite of this, should a lightning surge be violent enough to damage the lightning arrester, then the fuse will isolate the faulty equipment, leaving the feeding of the railway line in service.

One of the essential elements of the system is that it is the first with a distant warning signal of the lightning arrester being isolated. The railway network operator has the advantage of detecting very rapidly the protections.

Mersen proposes to use a zinc oxide varistor combined with a fuse and an electric signaling system. Thanks to this system, it is now possible.

FEATURES & BENEFITS

- To vastly improve the quality of power line protection by better peak let-through in overvoltage conditions. This is due to zinc oxide's non linearity factor, which is more suitable than silicon carbide's.
- To eliminate the now superfluous air spark-gap because leakage current is significantly reduced, making it easier to install the product.
- To lengthen the product's life span and improve peak let-through over time, because ZnO retains its initial properties better and longer.
- To avoid disturbing operation when the product has aged due to lightning striking too many times or too hard.
- To simplify maintenance. The defective device is immediately isolated and the blown fuse detection device trips a micro-switch to give remote warning of the state of the system. The element to be replaced is identified immediately.
- Operation : Instantaneous automatic, self-restoring, no power follow current, only voltage spikes clamped.
- Connections : No 8 AWG cables for plus and minus terminals.
- Gapless: no series components other than surge suppression fuses.
- Power consumption: none except few milliamperes for indicator lamps and relay coil.

APPLICATIONS

- Railway networks protection against disturbances incurred by lightning



10kA and 20kAmp Lightning Arrester

TECHNICAL DATA OVERVIEW

Voltage Range AC	500 ... 750 VAC
Breaking capacity	100kAmp surge fuse
Speed/Characteristic	1 nanosecond
Switchability	Bidirectionnal, same performance on either polarity
Working Temperature	-55°C to +85°C
Air quality	Salt-laden atmosphere, dry and dusty (0,1mm to 1mm airborne particules), any ozone condition, acid rain, presence of SO2
Humidity	95% non-condensing Maximum

TECHNICAL DATA

Surge Arrester

Max. operating voltage	900 VDC
Clamping voltage	1200 VDC
Clamping voltage vs surge current	0,1 kAmp peak - 1'245V clamping voltage 0,5 kAmp peak - 1'320V clamping voltage 1 kAmp peak - 1'340V clamping voltage 5 kAmp peak - 1'500V clamping voltage 10 kAmp peak - 1'700V clamping voltage 50 kAmp peak - 2'000V clamping voltage 100 kAmp peak - 2'400V clamping voltage 200 kAmp peak - 2'800V clamping voltage
Energy	55000
No. of operation	1000 Amp - N° of operations = infinte 5000 Amp - N° of operations = 500,000 10,000 Amp - N° of operations = 50,000 50,000 Amp - N° of operations = 5,000 100,000 Amp - N° of operations = 50 200,000 Amp - N° of operations = 5

DIMENSIONS

Surge arrester 10 kAmp (dwg 118386)

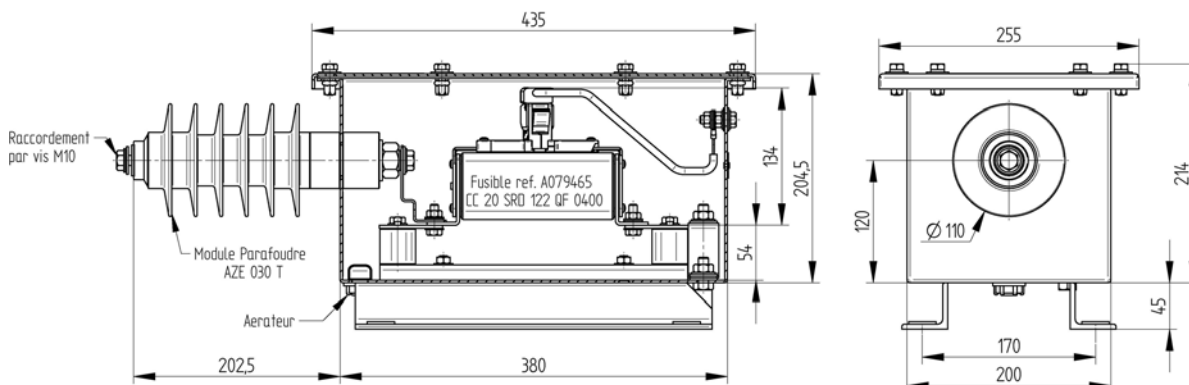

10kA and 20kAmp Lightning Arrester

DIMENSIONS

Surge arrester 20 kAmp (dwg 118515)

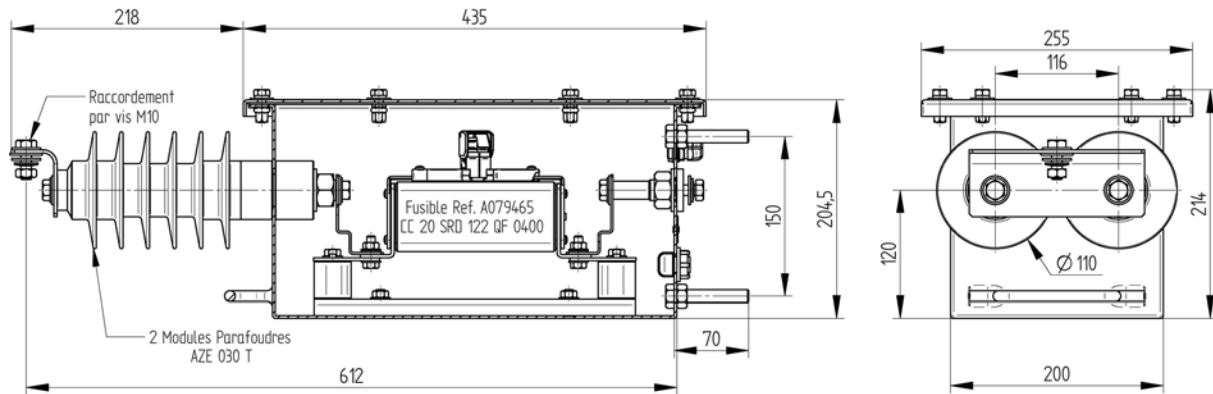

FUNCTIONS

Blown fuse indicator

Remote alarm relay, 110VDC Aux Contact.

Indicator Lamps

Each line on box cover.

Connections

N° 8 AWG cables for plus and minus terminals.

Operations

Instantaneous automatic, self-restoring, no power follow current, only voltage spikes clamped.

Gapless

No series components other than surge suppression fuses.

Power Consumption

None except few milliamperes for indicator lamps and relay coil.