

# SKPC340 OR SKPC350 3 PHASE THYRISTOR CONTROLLER

## FEATURES

- \*\* Controls a wide range of thyristors**
- \*\* Logic control**
- \*\* Optional current limit**
- \*\* Soft-start/stop, adjustable ramp up/down periods**
- \*\* Fully isolated input from output**
- \*\* Wide selection of supply voltages**
- \*\* Voltage or mA input, user selectable**
- \*\* Span & zero adjust for wide range of inputs**

The SKPC340 is designed for controlling either a B6C AC/DC fully controlled thyristor bridge or B6HK AC/DC half controlled thyristor/diode bridge.

The SKPC350 is designed for controlling either a W3C AC/AC full control or W3H half control configurations.

Voltage or mA source input is user selectable. Input span and offset are adjustable to allow flexibility for users to select different applications.

A 'LOGIC CONTROL' function allows to start/stop the output current/voltage. When a 340/350 is started by the 'Logic control' with a preset input signal, the output will gradually ramp up from zero to the preset level according to the ramp up period setting. However, the 'Logic control' will quench the output to zero instantly when it is at logic high (or logic input open circuit).

Both soft-start (ramp up) and soft-stop (ramp down) are standard features for SKPC340/350.

Current limit is the optional feature for a SKPC340/350. The output current can be limited to a preset safety level to protect the load from over current. This feature should be used for high inrush current loads, such as transformer coupled loads, capacitive loads and short wave infra-red heaters.

Wide ranges of different supply voltage are available as standard units. An isolated relay output is used for indicating when current limit is in action.

NOTE : For a satisfactory control system when using a SKPC340 or SKPC350 to control a thyristor stack, protection against voltage transients to the thyristor stack is essential especially controlling an inductive load such as a transformer coupled load or a motor.

Please refer to 'Semikron Power Semiconductor Handbook' Section 7 for selecting sufficient protection or contact our local sales office.

## WIRING AND SETTING INSTRUCTION

**1) INITIAL FACTORY SETTING** The following have been adjusted in our factory:

- a) SW2 at OFF position: short ramp; RAMP UP pot fully clockwise: approximately 1 to 2min. of ramp up time; RAMP DOWN pot fully anti-clockwise: minimum of less than 2sec. ramp down time.
- b) SW1 at OFF position also, OFFSET & SPAN pot is set to have full control for 0 to 10V input with resistive load. Re-just these pots are necessary for other range of input or inductive loads.
- c) SW3 is at "OFF" position & SW4 is at "ON" position.
- d) For unit with optional current limit: the 'LIMIT POT' was set to approximately 5A or 10A output current with current transformer CT-65 (1000:1 ratio) or CT-150 (2000:1) ratio correspondingly.

## 2) WIRING INSTRUCTION

'340 & 350 PANEL LAYOUT' (FIG.1) shows the function of each terminal block. All the terminal blocks are of plug-in type.

- a) Select one of the thyristor connection configurations according to figs. 4, 5 or 6.
- b) Use the minimum recommended wire size of 16/0.2mm sq cable, current rating of 3A, maximum working voltage of 1000Vac.
- c) After completing the wiring from the SKPC340 or SKPC350 to the thyristor stack, use a digital ohm meter to measure each corresponding K (cathode) and G (gate) (for example, resistance between K1 and G1; K5 and G5) resistance at the terminal of the plug-in plugs with and without the connectors being plugged into the SKPC340 or SKPC350. They should have the same value between 8 to 80 ohms.

With the same type and batch of thyristor, their gate to cathode resistance is generally very closely matched. For high sensitivity gate thyristors, resistance between the gate and cathode can be very high and more than 80 ohms.

- d) Check carefully the wiring from K2, K6 and K4 connected to the corresponding three phase supply.
- e) If LOGIC CONTROL function is not used, connect a wire link across the LOGIC CONTROL +ve and -ve terminals. Otherwise, the SKPC340 or SKPC350 will be disabled.

Link the logic input terminals (LOG+ & LOG-) to enable the output; for remote operation, use an externally connected on/off switch; or an open collector transistor logic from a programmer as shown in fig. 4.

**3) Potentiometer Functions** Refer to fig. 1 for the layout.

- ZERO (OFFSET) POT : Trims output to zero power for zero or certain level input.
- SPAN POT : Trims output to full power for maximum input.
- RAMP UP/DOWN ADJ : Adjust the ramp up/down time.
- I or V LIM POT : Adjust the current or voltage limit level.

**4) LED Indicators**

- LED LOG I/P Green colour: Logic input status - LED illuminates at logic low, output enable  
LED extinguishes at logic high, output is off.
- LED ON/OFF Amber colour : Power on; normally on.
- LED I/V LIM Red colour (optional): Current limit on; normally off.
- PHASE ROTATION Red colour (optional): For half control only, when the phase rotation of the three phase supply is correct, the LED is on.

**5) Piano Switch** - A 4 way piano switch allows users to select various functions.

	SW1	SW2	SW3	SW4	Note:
mA I/P	1	x	x	x	1 is ON, downward position 0 is OFF, upward position
long ramp	x	1	x	x	
open loop	x	x	0	1	
close loop	x	x	1	0	

X: depends on other functions, for example a unit with mA I/P, open loop control and standard ramp up time has the four switch position as SW1: 1; SW2: 1; SW3: 0 and SW4: 1.

**6) Logic control**

This provides logic on/off control and system 'quench' to the thyristor trigger pulses together with automatic soft-start, hence minimizing inrush current. This logic control may be used for emergency shutdown or remote control such as in welding applications. Refer to fig. 4 for connection.

**7) Current limit**

It is particularly suitable for restricting the current to a safe level during the warm-up period, especially in loads where the resistance may varies greatly from cold to hot. Potentiometer I LIM POT is used to set the current limit and the calibration procedure for it can be found in section 8.4.

**8) Potentiometer's and selection switch settings**

**8.1) I/P offset**

Generally no adjustment is necessary, as this is normally pre-calibrated at the factory. However, if it is necessary to re-calibrate, follow the following procedure:

- a) Set the input signal to minimum.
- b) Use a voltmeter to measure the load voltage or a current meter to measure the line current.
- c) Adjust I/P OFFSET POT clockwise until a minimum power is delivered to the load, then adjust I/P OFFSET POT counter-clockwise until the output is zero.
- d) Note: Since RC snubber network is fitted, there is a residual current appeared in the load. This is quite acceptable.

**8.2) I/P span pot**

Set the input signal to maximum, adjust I/P SPAN POT until output just gives full output (power).

### 8.3) Ramp up or down period adjust

Adjust the RAMP ADJ pot to fully clockwise, and if the response for the load current and voltage takes too long for the application, gradually turn RAMP ADJ pot counter clockwise to the desired ramp up or down period.

### 8.4) Current limit (I LIM)

Two current transformers are used to limit the load current. To set the current limit level, follow the following procedure:

- a) First set I LIM pot to fully counter clockwise.
- b) Set input signal to give full power.
- c) Use a current meter to monitor the desired line current.
- d) Gradually adjust I LIM pot clockwise to increase the current limit level to the desired value. If long ramp up period is selected, allow sufficient time for the input to ramp up to its maximum value before adjusting I LIM pot.
- e) Observe I LIM LED illuminates to indicate current limit is in action.
- f) Reduce input signal until I LIM LED is off.
- g) This completes the current limit setting.

### 8.5) Closed loop control with VF option:

The closed loop control with VF option is used to give a constant output with a set demand.

The demand is nominally 0-10V dc. Any load impedance or supply voltage variation should not affect the output, which will remain constant.

There are two input terminals with this option, VF and VX. Terminal VF allows feedback voltage in the range of 0 to 30Vdc to be used. Terminal VX is used for feedback voltages in excess of 30V dc. A feedback resistor is connected between VX and VF, R F/B.

The value of R F/B is

$$R F/B = [(\text{feedback voltage} - 6) / 6 - 3.9] \text{ kilo-ohm}$$

$$\text{Power dissipation of R F/B} = (\text{feedback voltage}) * (\text{feedback voltage}) / (R F/B * 1000)$$

For example, a B6C controller has a max. output voltage of 560Vdc, the R F/B is 88.43 Kilo-ohm, a 91 kilo-ohm resistor can be used. The power dissipation of R F/B is 3.44 watts, a 6 watts resistor should be used. Since the voltage across the resistor and the heat dissipation are high, it is better to fit this resistor outside the PC340/350 enclosure.

Other feedback voltage or currents can be accommodated (eg. mV signals (shunts), 4-20mA current loops etc.). Please consult our sales office.

- a) Set SW3 'ON' and SW4 to 'OFF' position which set the controller to close loop control.
- b) Use a voltage meter or current meter (true RMS meter is preferred) to monitor the desired line voltage or current.
- c) Gradually increase the input signal to about 10% of the max. value. If long ramp up period is selected, allow sufficient time for the input to ramp up to its set value. Observe the output voltage or current, it should increase with the input gradually. If the output keeps increasing, the voltage feedback signal may not be connect properly, check the feedback voltage polarity and connection.
- d) If the output voltage or current is varying according to the input signal, increase the input to maximum, adjust the 'SPAN' pot to give the desire output voltage.

### 9) Half Control

For a SKPC340 or SKPC350 having B6H or W3H control configuration, the control unit must connected to the 3 phase supply with the correct phase rotation in order to generate the correct switching sequence for the thyristors.

With the logic input at logic high or open circuit to inhibit the output, connect and switch on the 3 phase supply to the SKPC340/350, if the 'PHASE ROTATION red LED' illuminates (ON), the phase rotation is correct. If the LED extinguishes, the phase rotation is wrong. Switch off the 3 phase mains supply, swap any two of the phase supply. Switch on the 3 phase supply, the 'PHASE ROTATION red LED' should illuminate (ON), the phase rotation is correct.

# SKPC340 OR SKPC350 SPECIFICATION

## INPUT

Voltage 0-10V as standard, 0-5V to 0-15V.  
zero & span pots used to set I/P range  
Impedance 100 K ohm min.  
Max. input current 25Vdc  
4-20mA, 270 ohm max, set SW1 to ON (1)  
position for current input  
Aux 10V output 10V +/-5%, 3mA max.

## SUPPLY

Line/line voltage specified value, +/-10%  
Frequency 47 to 63 Hertz  
Power 3 X 3VA

## OUTPUT

Output 6 isolated pulse outputs  
Current 350mA peak, refer to fig. 2  
Isolation 2500Vrms between I/P & O/P

## ENCLOSURE

Material zinc plated colour passivated steel enclosed  
Dimensions 250mm (W), 235mm (D), 75mm (H)  
Mounting See fig. 3

## ENVIRONMENT

Operating temp. 0 to 50 Deg. C  
Storage temp. -20 to 70 Deg. C  
Relative humidity 0 to 85%

## SOFT-START AND SOFT-STOP

Soft-start Standard ramp-up period - from 1 to 30sec.  
& Ramp-up Long ramp-up period - from 10 sec. to 4 min.  
Separate Ramp-down adjust: same adjustable range as  
ramp-up range period.

## LOGIC CONTROL (system quench)

Logic low Active low, (output enable) less than 0.7Vdc  
or input short-circuit  
Logic high Output off, greater than 3.6Vdc (30Vdc  
max.) or input open-circuit

## OPTIONAL FEATURE - CURRENT LIMIT

6A to 65A line current : use CT-65 current transformer.  
12A to 150A line current : use CT-150 current transformer.

Over 150A, please contact our sales office

Response time Within 2 seconds  
Indication Red LED; normally off  
Indication output Isolated relay output, 240Vac, 1A rms.  
VOLTAGE LIMIT (only supply as special unit, please  
contact our sales office)

Note: Non-isolated, however, the leakage current is less  
than 1mA which has no harmful effects to users. For  
total isolation between input signal and output,  
signal isolator can be used.

Voltage limit range : 50V to 240Vrms 3 phase, for higher voltage,  
external voltage divider should be used to limit the feedback  
voltage to the SKPC340 or 350.

ORDERING INFORMATION FOR SKPC340 AC/DC 3 PHASE THYRISTOR CONTROL UNIT

	SKPC340	---	L/L---	---	
			:	:	:
3 PHASE	e.g. 415V		415V	:	:
LINE TO LINE				:	:
VOLTAGE				:	:
SUPPLY VOLTAGE IMMEDIATE				:	:
AVAILABLE ARE:	24V, 120V			:	:
	240V, 380V, 415V			:	:
	440V, 500V, 600V			:	:
	660V			:	:
For other supply voltage,				:	:
please specified.				:	:
CONTROL CONFIGURATION				:	:
SIX-PULSE FULL CONTROL BRIDGE	-B6C		B6	:	:
HALF CONTROL BRIDGE	-B6HK		B6H	:	:
EXTRA OPTION				:	SS
ADJUSTABLE CURRENT LIMIT					

ORDERING INFORMATION FOR SKPC350 AC/AC 3 PHASE THYRISTOR CONTROL UNIT

	SKPC350	---	L/L---	---	
			:	:	:
3 PHASE	e.g. 415V		415V	:	:
LINE TO LINE				:	:
VOLTAGE				:	:
SUPPLY VOLTAGE IMMEDIATE				:	:
AVAILABLE ARE:	24V, 120V			:	:
	240V, 380V, 415V			:	:
	440V, 500V, 600V			:	:
	660V			:	:
For other supply voltage,				:	:
please specified.				:	:
CONTROL CONFIGURATION				:	:
FULL CONTROLLABLE 3 PHASE	- W3C		W3	:	:
HALF CONTROL	- W3H		W3H	:	:
EXTRA OPTION				:	SS
ADJUSTABLE CURRENT LIMIT					

Current transformers (2 per unit) for 'Current Limit'

FOR LINE CURRENT OF 6A TO 65A

CURRENT TRANSFORMER TYPE : CT-65, INTERNAL DIA.: 10mm

FOR LINE CURRENT OF 12A TO 150A

CURRENT TRANSFORMER type : CT-150, INTERNAL DIA.: 15mm

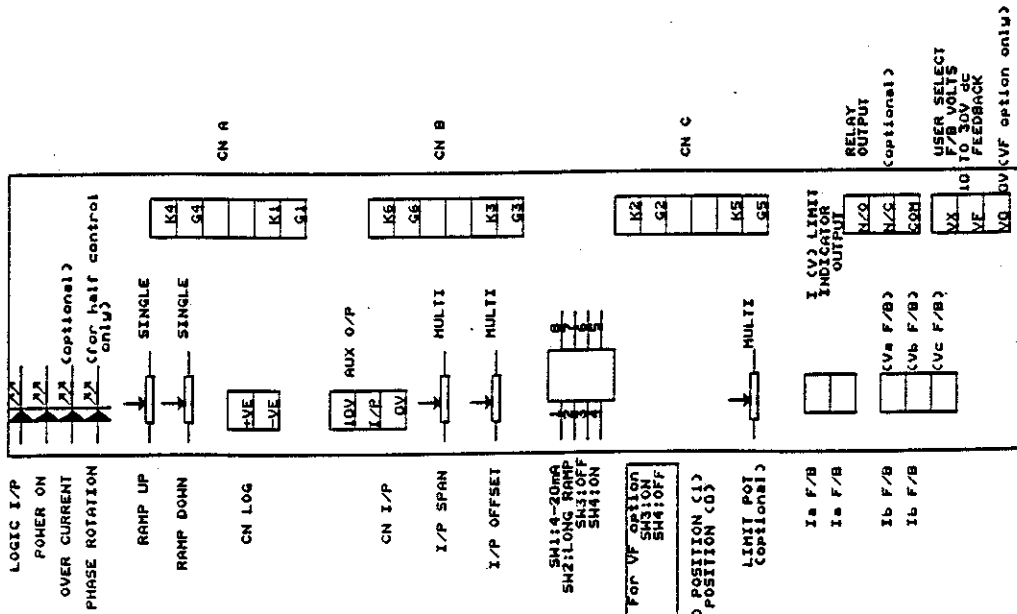

SKPC340 & 350  
PANEL LAYOUT

FIG.1

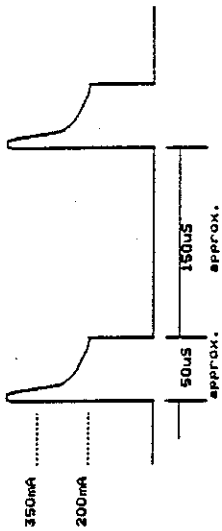

THYRISTOR GATE PULSES CURRENT  
WAVEFORM WITH A 10 OHMS LOAD

FIG.2

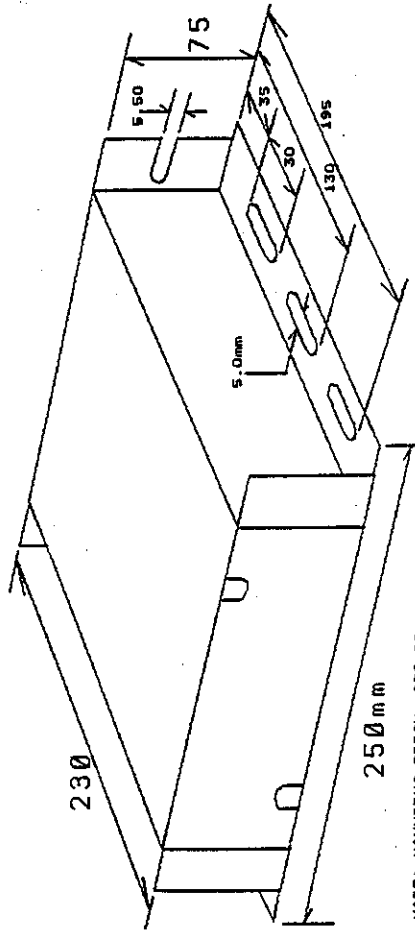

NOTE: MOUNTING PITCH: 230.00mm

FIG.3 ENCLOSURE FOR SKPC340/350

Title

340 & 350 INS FIG.1 & 3

Size Document Number

CD0606B.SCH

Date

June 22, 1995 Sheet 1 of 1

REV

B

D

LOG INPUT

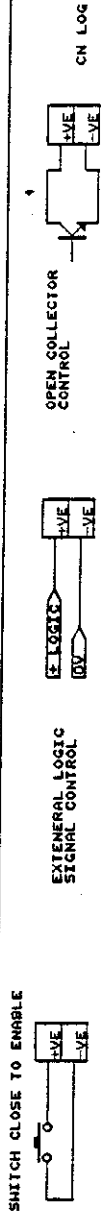

INPUT\_CN

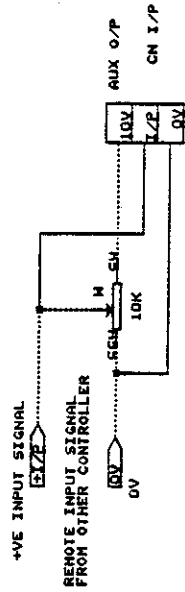

V OR I LIMIT INDICATOR O/P

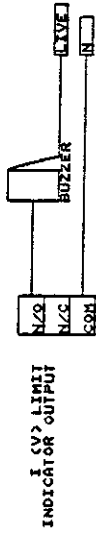

OPTIONAL CURRENT LIMIT CONNECTIONS

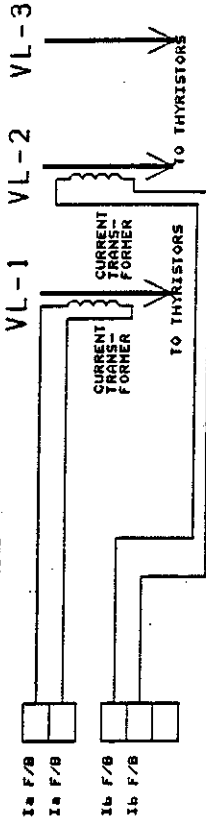

V f/b OPTION ONLY

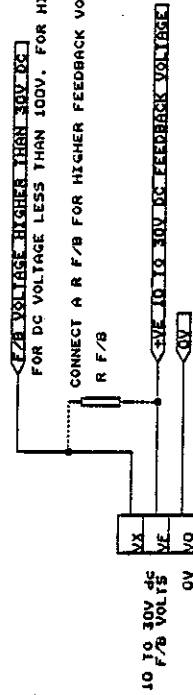

R F/B = (FEEDBACK VOLTAGE - 6.7V) - 3K9 KILO-OHM

a) FOR CONSTANT VOLTAGE CONTROL, WITH MAX. INPUT SIGNAL, SWS AT ON AND SH4 AT OFF POSITION, ADJUST I/P 'SPAN' POT TO GIVE MAX. OUTPUT CONTROL VOLTAGE.

WITH INPUT AT MIN. LEVEL, ADJUST ZERO POT TO GIVE ZERO OUTPUT.

b) FOR TESTING THE CONTROLLER WITHOUT FEEDBACK SIGNAL, PUT SWS AT 'OFF' AND SH4 AT 'ON' POSITION, IT THEN SELECT THE CONTROLLER WORKING AT OPEN LOOP CONTROL. THE OUTPUT FOLLOWS THE INPUT SIGNAL.

FIG. 4

REV	DATE
A	21 MAR-90
B	APR 1-90
C	MAR-91
D	JUNE-95

FILE	CONTROL SIGNAL CONNECTION DIA. FOR PC340/350
SIZE	Document Number
u	C06011D.SCH
Date	June 27, 1995
of	1

FIG. 5 SKPC350 W3C WIRING DIAGRAM

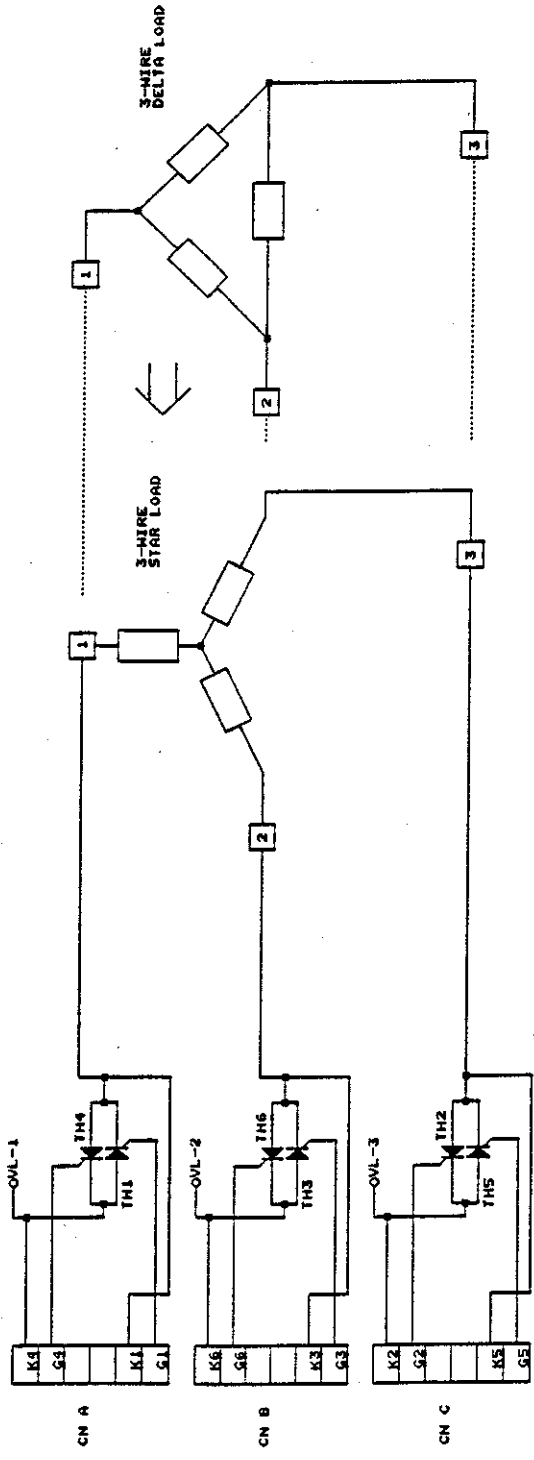
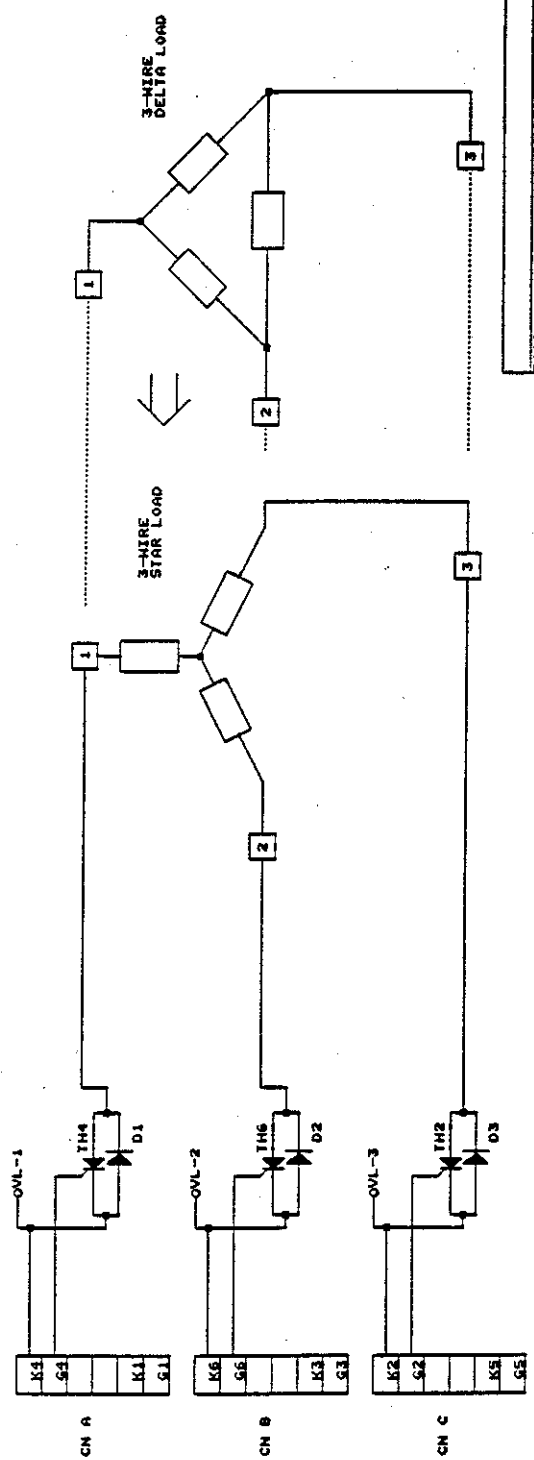

FIG. 6 SKPC350 W3H WIRING DIAGRAM



FILE#	SKPC350 W3C W3H WIRING DIAGRAMS	REV
SIZE	Document Number	B
	CD6063A.SCH	A
DATE	April 4, 1991	1 of 1



FIG. 7 BEC WIRING DIAGRAM

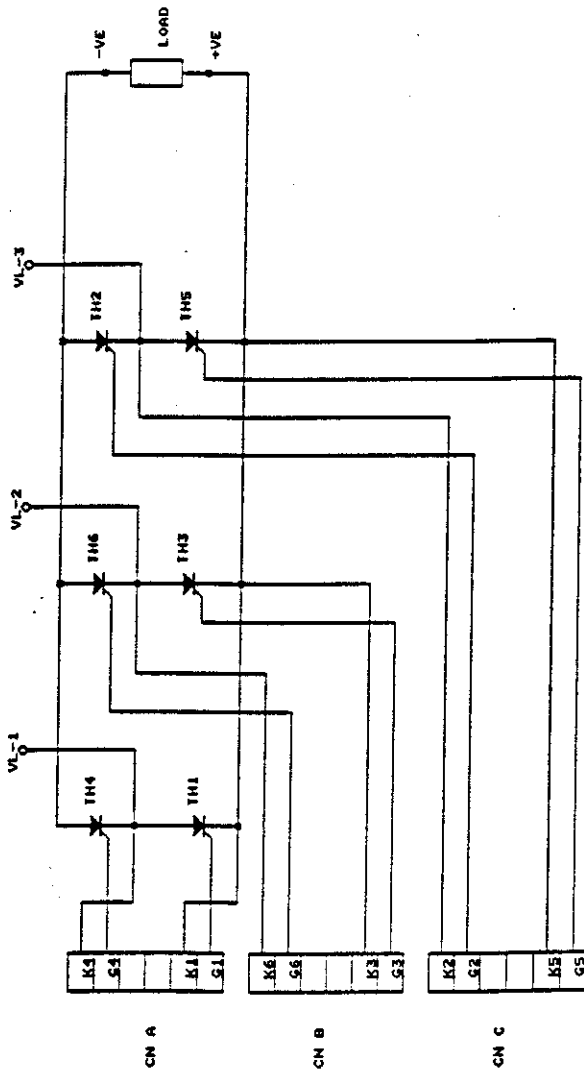
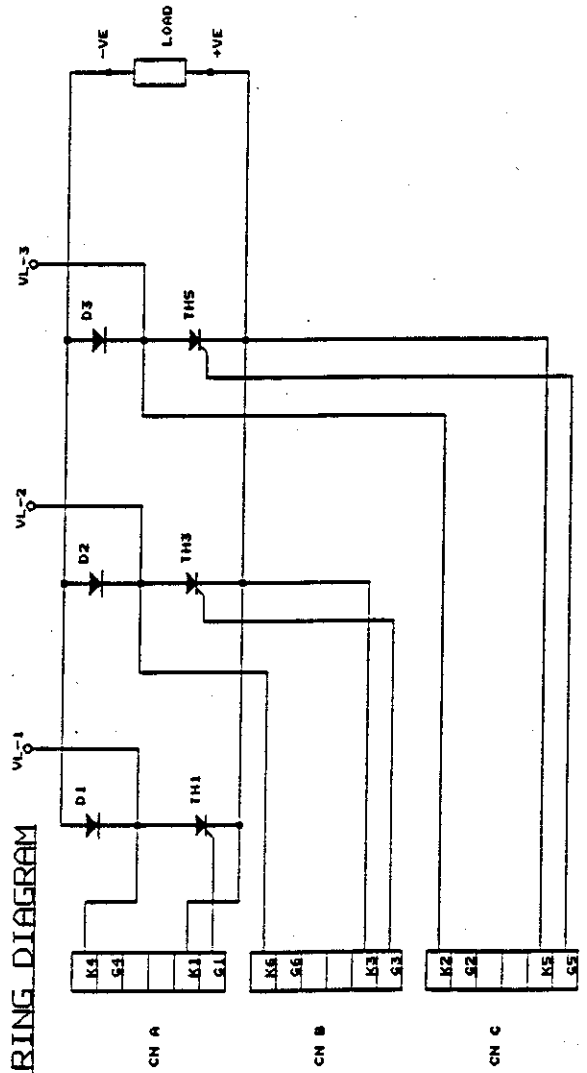
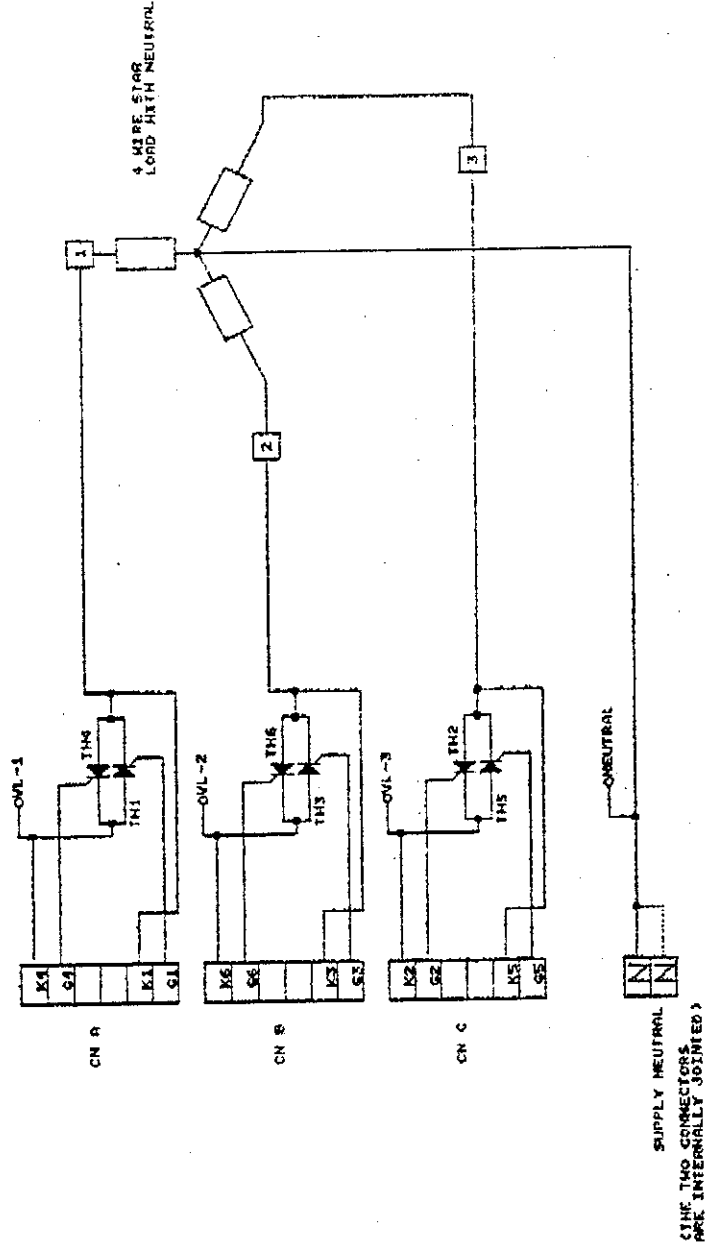

FIG. 8 B6HK WIRING DIAGRAM



TITLE	SKPC340 BEC B6HK WIRING DIAGRAM
SIZE	Document Number
REV	0
DATE	APR 17, 1971
BY	WJL/MSJ
OF	01

FIG. 5 SKPC350 WIRING DIAGRAM FOR 4 WIRE STAR LOAD WITH NEUTRAL



SKPC350	
TABLE	WIRING FOR 4 WIRE STAR WITH NEUTRAL LOAD
SIZE	DOCUMENT NUMBER
B.	CONTRACT NO.
DATE	APPROVED BY